

# EDM3E Servo Drive



**ECO-DRIVE MAX**

# Table of Contents

<b>Table of Contents</b> .....	<b>1</b>
<b>Features</b> .....	<b>2</b>
<b>Terminal Description</b> .....	<b>3</b>
<b>Connection Diagram</b> .....	<b>4</b>
<b>Specifications</b> .....	<b>5</b>
Core Specification.....	5
EtherCAT Slave Specification.....	6
Performance Specification.....	7
Signal and Function Specification.....	8
<b>Model Information</b> .....	<b>9</b>
<b>Drive and Motor Matching Table</b> .....	<b>10</b>

## Features

- Single-phase 220V~240V 0.1~1kW
- Three-phase 220V~240V 0.75~1.5kW
- Three-phase 340V~460V 1.5~30kW
- High-speed Response
- Bus Control
- High-precision Tuning
- Easy to use

The power range of this series of products is 50W~7.5KW. It features an ethernet communication interface, supports either CAT CoE communication protocol (CA301, CA402), and cooperates with the host computer to realize the network operation of the platform server.

It provides rigid table settings, inertial table recognition and vibration suppression functions, making the servo drive easy to use. With the servo motor of 17-bit incremental programmer and 23-bit absolute value programmer, the operation is stable, the response is fast, and the positioning is accurate

It is suitable for automation equipment such as semiconductor manufacturing equipment, robotics, metal processing machine tools and transmission machinery to achieve fast and accurate collaborative control.

# Terminal Description

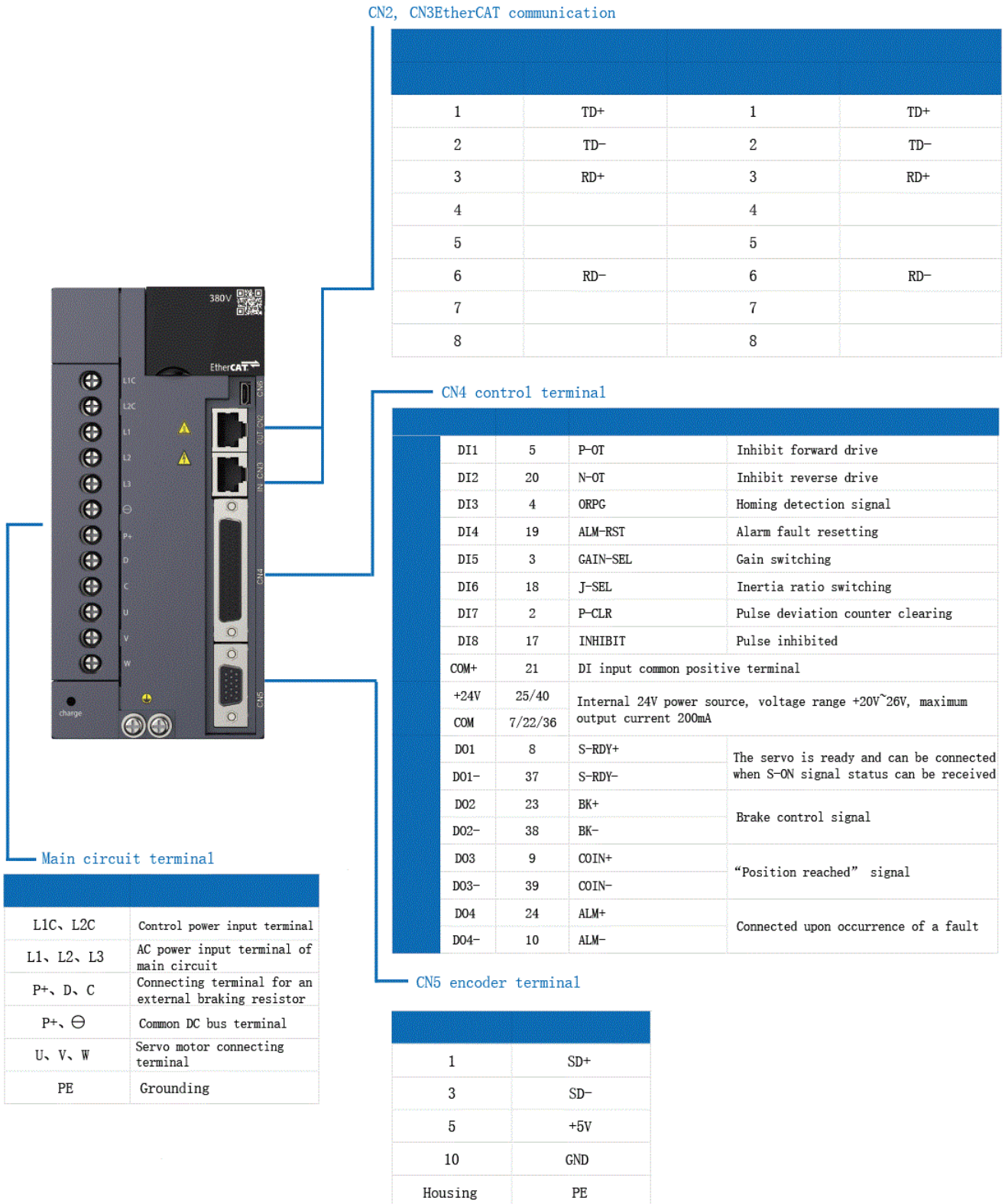

CN2, CN3 EtherCAT communication

1	TD+	1	TD+
2	TD-	2	TD-
3	RD+	3	RD+
4		4	
5		5	
6	RD-	6	RD-
7		7	
8		8	

CN4 control terminal

DI1	5	P-OT	Inhibit forward drive
DI2	20	N-OT	Inhibit reverse drive
DI3	4	ORPG	Homing detection signal
DI4	19	ALM-RST	Alarm fault resetting
DI5	3	GAIN-SEL	Gain switching
DI6	18	J-SEL	Inertia ratio switching
DI7	2	P-CLR	Pulse deviation counter clearing
DI8	17	INHIBIT	Pulse inhibited
COM+	21	DI input common positive terminal	
+24V	25/40	Internal 24V power source, voltage range +20V~26V, maximum output current 200mA	
COM	7/22/36		
D01	8	S-RDY+	The servo is ready and can be connected when S-ON signal status can be received
D01-	37	S-RDY-	
D02	23	BK+	Brake control signal
D02-	38	BK-	
D03	9	COIN+	"Position reached" signal
D03-	39	COIN-	
D04	24	ALM+	Connected upon occurrence of a fault
D04-	10	ALM-	

CN5 encoder terminal

1	SD+
3	SD-
5	+5V
10	GND
Housing	PE

Main circuit terminal

L1C、L2C	Control power input terminal
L1、L2、L3	AC power input terminal of main circuit
P+、D、C	Connecting terminal for an external braking resistor
P+、⊖	Common DC bus terminal
U、V、W	Servo motor connecting terminal
PE	Grounding

# Connection Diagram

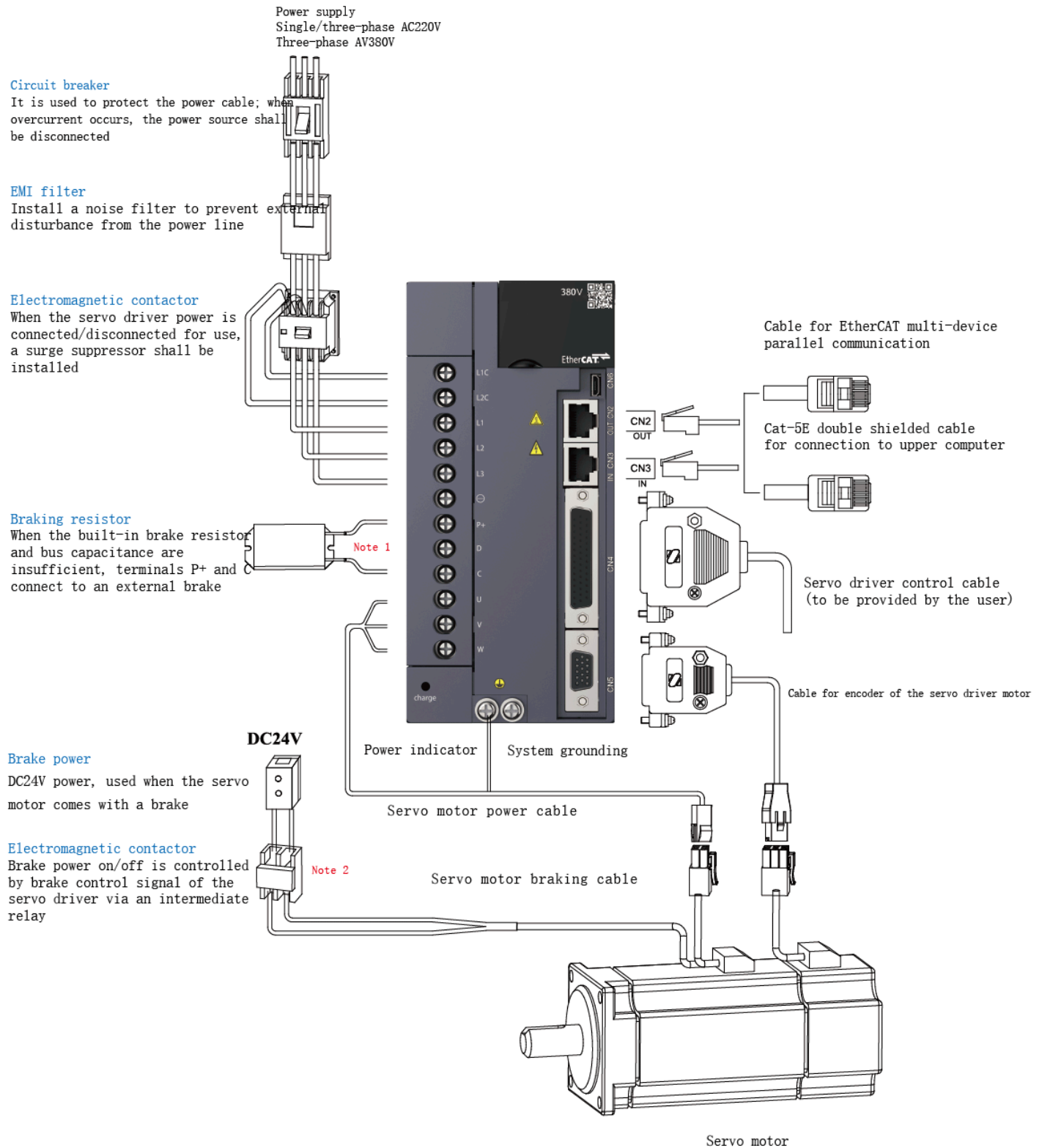

# Specifications

## Core Specification

Control Method		IGBT: PWM Control, Sine-Wave current drive type 220V, 380V: Single Phase or Three Phase Full Wave Rectifier
Encoder Feedback		17bit Serial incremental encoder, 23bit Serial absolute encoder
Front Panel		5 Keys, 5 Digit LED Display, Main power charge
Regenerative Brake		Can be built in and externally installed
Use Conditions	Environment Temperature	Working temperature: 0~40°C
	Ambient Humidity	Working/Storage: ≤ 90% RH (without dew condensation)
	Anti-Vibration & Anti-Impact Strength	$4.9m/s^2$ & $19.6m/s^2$
	Protection Level	IP10
	Pollution Level	Level 2
Cooling Method		Fan cooling

## EtherCAT Slave Specification

EtherCAT Basic Specification	Communication Protocol	EtherCAT Protocol
	Support Services	CoE (PDO, SDO)
	Instruction Synchronization Cycle	1ms or its integral multiple
	Synchronization Method	Distributed Clock
	Physical Layer	100BASE-TX
	Baud Rate	100MBit/s
	Duplex Mode	Full Duplex
	Topological Structure	Linear
	Transmission Medium	Shielded Cat-5E or better network cable
	Transmission Distance	Less than 50m between two nodes
	Quantity of Slave Stations	No more than 100
	EtherCAT Frame Length	44~1498 bytes
	Process Data	44~1498 bytes
	Communication Bit Error Rate	1/1000000000
EtherCAT Configuration Unit	FMMU Unit	4
	Storage Synchronization Management Unit	4
	Process Data RAM	4K
	Distributed Clock	64 digits
	EEPROM Capacity	16K
	Supported Running Mode CIA402	Profile Position Mode Profile Velocity Mode Profile Torque Mode Interpolation Position Mode Cyclic Synchronous Position Mode Cyclic Synchronous Velocity Mode Cyclic Synchronous Torque Mode Homing Mode

## Performance Specification

Speed-Torque Control Mode	Speed Fluctuation Ratio	Load Fluctuation	At 1~100% load: Maximum 0.3%	At rated speed
		Supply Voltage Charge	At rated voltage $\pm$ 10%: Maximum 0.3%	
		Environment Temperature	0~50°C: Maximum 0.3%	
	Speed Regulation Ratio		1:5000	Minimal speed/rated rotating speed of continuous stable operation under rated load
	Frequency Bandwidth		1.0KHz (17bit and 23bit encoder)	
	Torque Control Accuracy		$\pm$ 3% (current repetition accuracy)	
	Soft Start Time Setting		0~30s (acceleration and deceleration can be set respectively)	
Position Control Mode	Feedforward Compensation		Resolution 0~100% (set resolution 1%)	
	Positioning Completion Width		1~655,335 instruction units (set resolution 1 instruction unit)	
	Min Setting Time		5ms (no load, from rated speed to positioning completion)	



## Signal and Function Specification





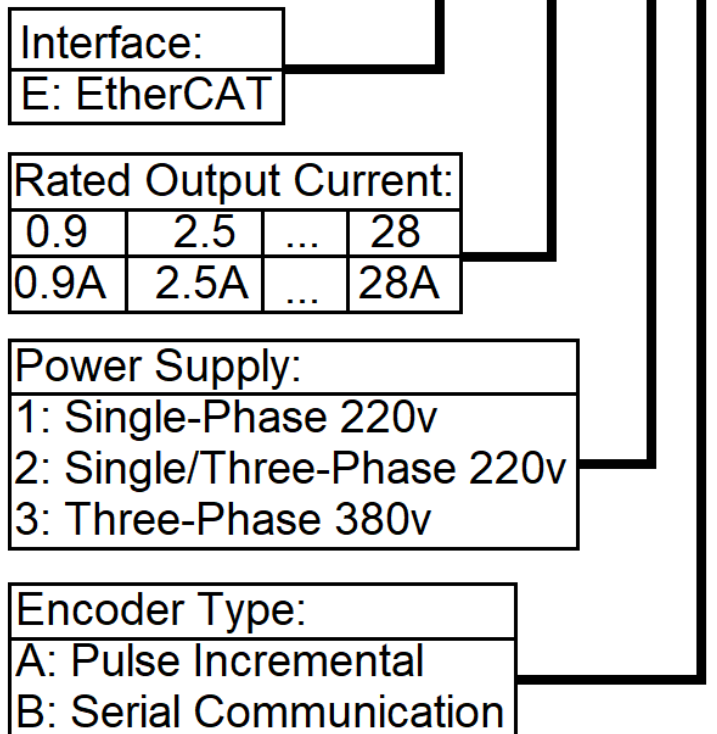

Digital Input Signal	Function Allocation Available	Servo enable, alarm reset, pulse deviation counter clearing, speed command direction selection, position/speed multi-segment switching, internal command trigger, control mode switching, pulse disable, forward drive disable, reverse drive disable, forward inch, backward inch
Digital Output Signal	Function Allocation Available	Servo ready, brake output, motor rotation output, zero-speed signal, speed approach, Speed reached, position approach, torque limit, rotating speed limit, warning output, alarm output
Over-Travel (OT) Prevention Function		Stopped immediately when P-OT and N-OT are activated
Electronic Gear Ratio		$1.0 \leq B/A \leq 64000.0$
Protective Function		Over-voltage, under-voltage, over-speed, overload, Over-temperature, encoder alarm, braking resistor overload alarm, excessive position error, EEPROM alarm, abnormal communication, etc
RS232 Communication		Status display, user parameter setting, monitoring display, alarm tracking display, JOG operation and automatic tuning operation, speed and torque instruction signal, etc
Other		Gain adjustment, alarm record, JOG Operation







## Model Information

# EDM3E-0.9-1B



## Drive and Motor Matching Table

Servo Drive			Motor		
EDM3E	Model	Supply Voltage	Motor	Power	Adaptable Motor Model
Size A 	EDM3E-0.9-1B EDM3E-1.6-1B EDM3E-2.5-1B	Single-Phase AC220v		50w 100w 200w 400w	EDM04-0.05-30-2FY EDM04-0.1-30-2FY EDM06-0.2-30-2FY EDM06-0.4-30-2FY
Size B 	EDM3E-4.8-2B EDM3E-6.2-2B	Single-Phase / Three-Phase AC220v		750w 1000w	EDM08-0.7-30-2FY EDM08-1.0-30-2FY EDM13-1.1-20-2FY
Size C 	EDM3E-5.6-3B EDM3E-8.5-3B EDM3E-13-3B	Three-Phase AC380v	 	850w 1.3kw 1.7kw  1.8kw 2.4kw 2.6kw 2.9kw 3.6kw	EDM13-0.8-15-3FY EDM13-1.3-15-3FY EDM13-1.7-30-3FY EDM13-1.1-20-3FY EDM13-1.7-20-3FY EDM13-2.6-30-3FY EDM13-1.8-15-3FY EDM13-2.4-20-3FY EDM13-3.6-30-3FY EDM13-2.9-15-3FY

<p>Size C</p>		<p>EDM3E-11-2B</p>	<p>Three-Phase AC220v</p>		<p>0.8kw 1.1kw 1.7kw</p>	<p>EDM13-1.1-20-2FY EDM13-0.8-15-2FY EDM13-1.7-30-2FY</p>
<p>Size D</p>		<p>EDM3E-17-3B EDM3E-22-3B EDM3E-28-3B</p>	<p>Three-Phase AC380v</p>		<p>4.4kw 5.5kw 7.5kw</p>	<p>EDM18-4.4-15-3FY EDM18-5.5-15-3FY EDM18-7.5-15-3FY</p>
					<p>11kw 13kw 15kw</p>	<p>EDM20-011-15-3FY EDM20-011-20-3FY EDM20-013-15-3FY EDM20-015-15-3FY EDM23-011-15-3FY</p>
<p>Size E</p>		<p>EDM3E-38-3B EDM3E-52-3B EDM3E-62-3B</p>	<p>Three-Phase AC380v</p>		<p>15kw 18kw 22kw 29kw</p>	<p>EDM23-015-15-3FY EDM23-018-15-3FY EDM23-022-15-3FY EDM23-029-15-3FY</p>